



Byers Cam Trak (Unofficial) Manual

Dave Kodama - 4/10/2003

[Home Page](#) | [Astrophotos](#)
Email: kodama@alumni.caltech.edu

This is an unofficial manual for the Byers Cam Trak single-axis star tracking camera mount. According to knowledgeable sources, no official manual ever actually existed so this writeup was created to go along with a unit available for loan to members of the Orange County Astronomers.

Contents

- [Components](#)
- [Tripod Assembly](#)
- [Tracker Setup](#)
- [Polar Alignment](#)

D. Kodama © 2003



Byers Cam Trak (Unofficial) Manual

[Contents](#) | [Cam Trak Components](#) | [Tripod Assembly](#) | [Tracker Setup](#) | [Polar Alignment](#)

The Byers Cam Trak consists of a tracking camera mount assembly which sits on a tripod base. It may be used on a sturdy flat surface such as a picnic table, or on the custom tripod. Everything but the tripod fits in a custom Byers case. All parts are shown laid out below. These parts include:

- Tracker assembly
- Camera platform / counterweight bar
- Power cord and electronics
- Counterweights (3)



Click to enlarge.



D. Kodama





Byers Cam Trak (Unofficial) Manual

[Contents](#) | [Cam Trak Components](#) | [Tripod Assembly](#) | [Tracker Setup](#) | [Polar Alignment](#)

Tracker Setup

If the tripod is not being used, rough-align the tracker mount by first setting the latitude scale (west side of tracker) to match your location. Loosen the screw on the opposite side of the tracker if this must be adjusted. Then set the the tracker on a stable, level surface (use the built-in bubble level).

Set up the rest of the tracker by sliding the camera/counterweight bar through the hole at the high end of the Cam Trak RA axis and tighten the knob at the end to hold the bar in place. Then attach the counterweights and camera to the bar.

To point the camera in the desired direction, loosen the two clutch knobs (see photo above) to rotate in the RA direction or loosen the counterweight bar clamp to rotate in the Dec axis. If more flexibility in framing the shot is necessary, add a ball head adapter under the camera.

Finally, connect the power cord to the mount at the mini-audio plug connector. And as a last step, plug the 12V car accessory power connector into a 12V battery or DC12V power supply. The tracker should be tracking at this point, and the polar finder reticle should be illuminated.

Official Cam Trak Diagrams (courtesy of Jim Fakatselis):

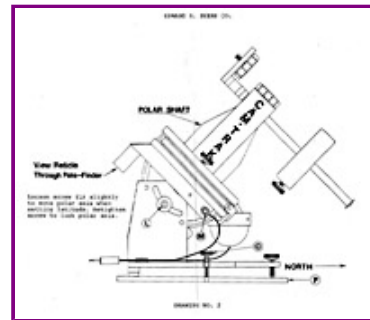
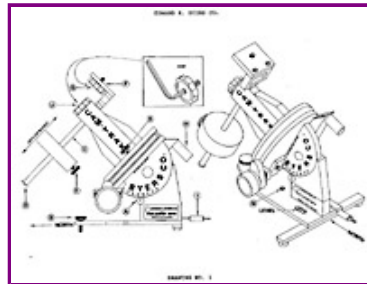
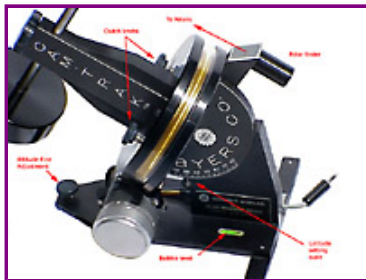

D. Kodama © 2003

EDWARD R. BYERS CO.

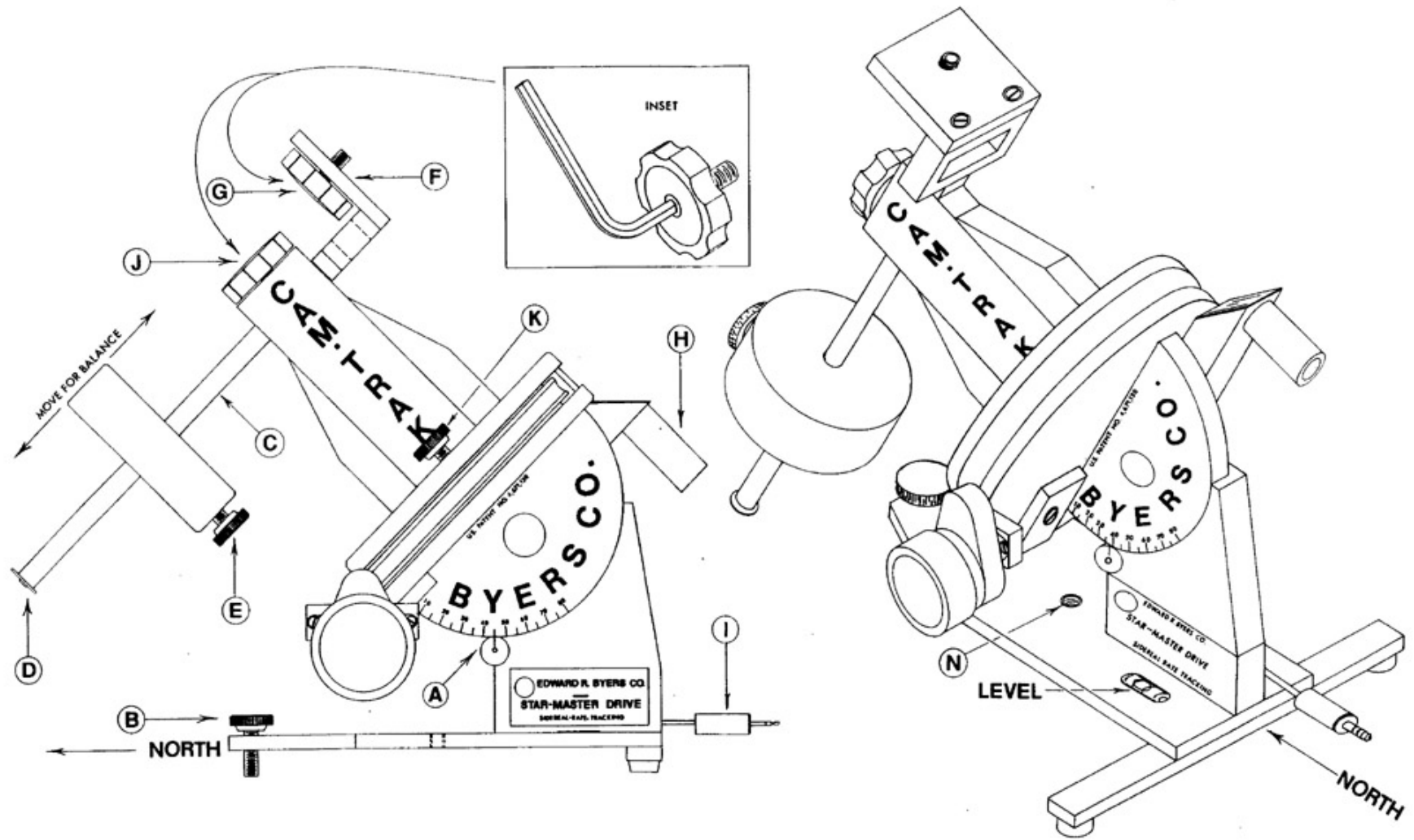

DRAWING NO. 1

EDWARD R. BYERS CO.

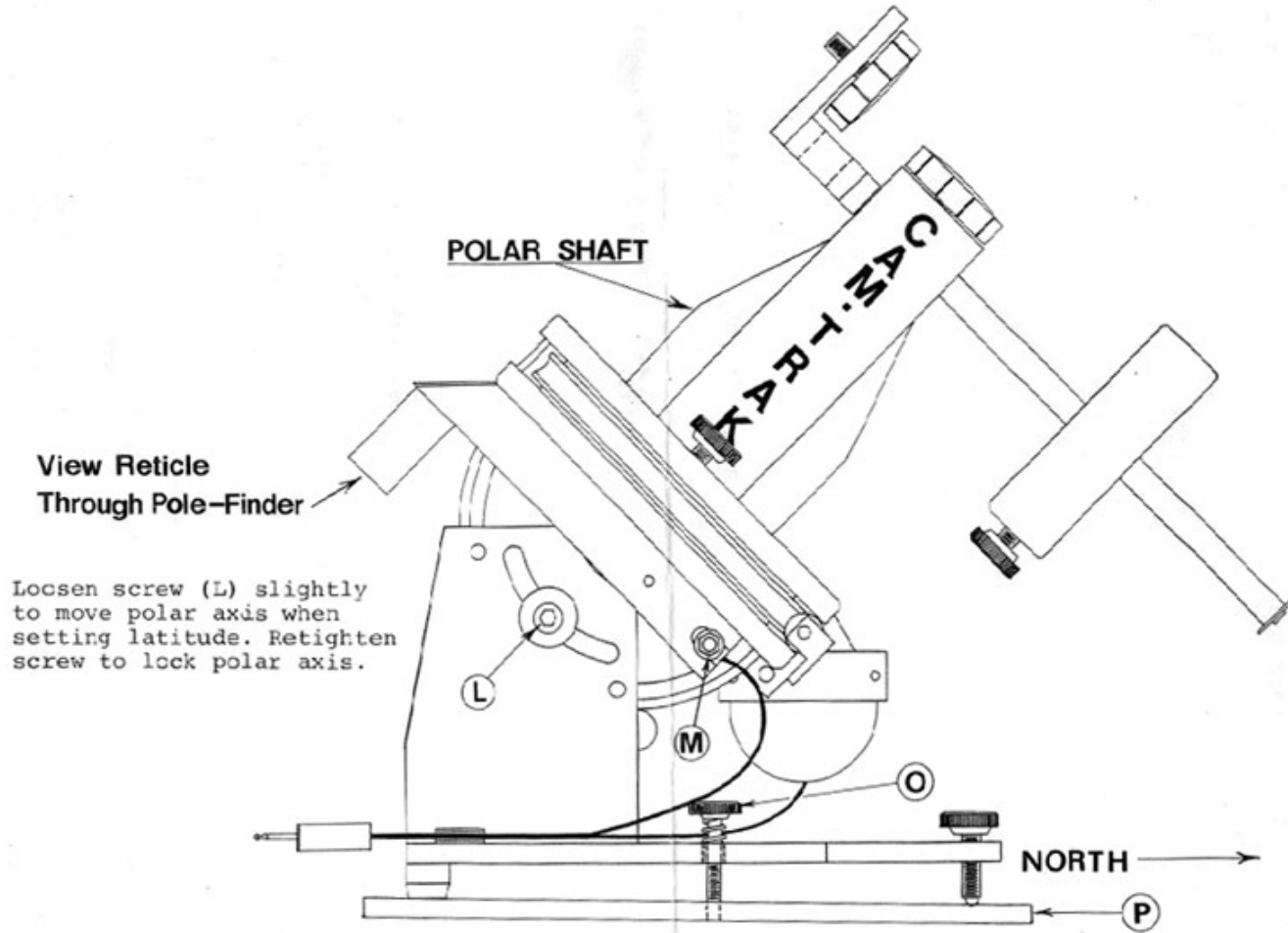

Loosen screw (L) slightly to move polar axis when setting latitude. Retighten screw to lock polar axis.

DRAWING NO. 2



Byers Cam Trak (Unofficial) Manual

[Contents](#) | [Cam Trak Components](#) | [Tripod Assembly](#) | [Tracker Setup](#) | [Polar Alignment](#)

Final Polar Alignment

The Cam Trak includes a 1x (non-magnifying) polar alignment "scope" which projects a target pattern on the sky as seen at right. Do not place your eye up against it as for an eyepiece, but instead, view from a few inches back. The intensity of the reticle pattern may be adjusted by turning the potentiometer at the base of the polar finder (east side of the mount).

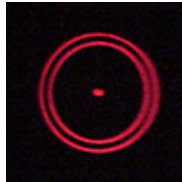

For maximum accuracy, you must determine the position angle of Polaris relative to the celestial pole and place it in the space between the reticle circles at the calculated angle. When this is done, the red dot at the center is where the celestial pole is located, and the mount has been aligned.

For some Cam Trak units, a plastic circular slide rule type calculator was provided to facilitate calculating the position angle of Polaris. If this is not available, use the chart at right to roughly determine the position angle.

The key relationship is the line between the end star of the Big Dipper's handle (Alkaid/ Eta) and Epsilon Cassiopeia. Polaris is very nearly on that line, displaced towards Cassiopeia. So to use the chart, rotate it until the positions of the Big Dipper and Cassiopeia match the actual arrangement in the sky, determine the line described above, and note the proper position of Polaris as it should appear in the reticle. Now fine tune the position of the tracker to place Polaris in the reticle annulus in the position determined from the chart. Once Polaris is positioned in the reticle to match, the Cam Trak is polar aligned.

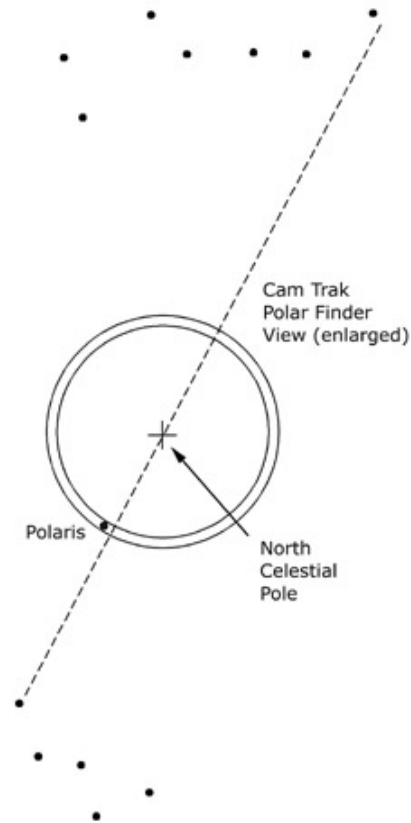

For fine adjustment of azimuth to achieve polar alignment, loosen the spring-loaded center screw holding the tracker to the tripod and carefully rotate the tracker on top of the tripod. Use the adjustment knob at the north end of the tracker to make fine adjustments of the altitude.

Congratulations! The Cam Trak setup is now complete and ready for use.*

Note: If you have not taken astrophotos with a tracking mount such as the Byers Cam Trak, see ["A Quick Start Intro to Wide Field Astrophotography"](#) for some tips to get started.